

INSTRUCTIONS FOR INSTALLATION

Kabe Casting Frames – assembled on site

Kabe 12R, 17R, 20R, 22R and 25R – Screw joint frame

Assemble the frame using enclosed screw and washer. Measure the diagonal distances of the frame to check that the corners are at right angles. For larger frames, counter-stays, e.g. wooden battens, may need to be sawn to fit on site to prevent the frame from taking a “hour-glass” shape, which could mean that the mat will not drop into the frame.

Each corner is to be joined using:

- 1 x washer (**1**)
- 4 x bolts (**2**)
- 4 x nuts (**3**)

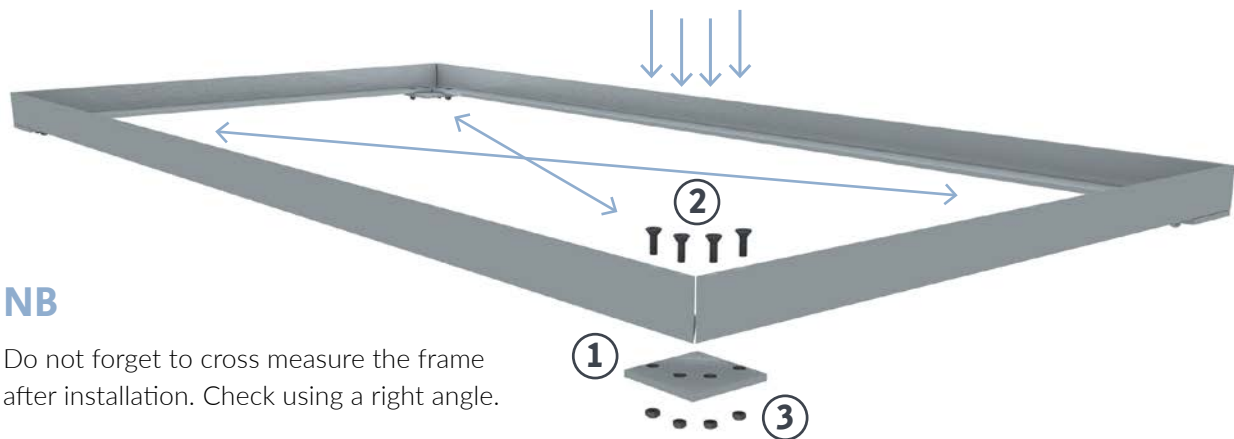

NB

Do not forget to cross measure the frame after installation. Check using a right angle.

Profiles

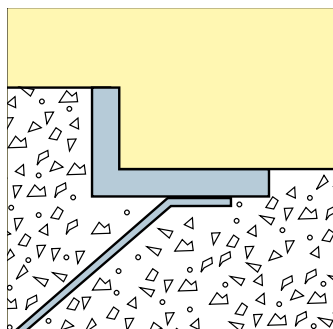

Kabe 12R

For mats height 10-14 mm.
Profile 16 x 26 x 4 mm.

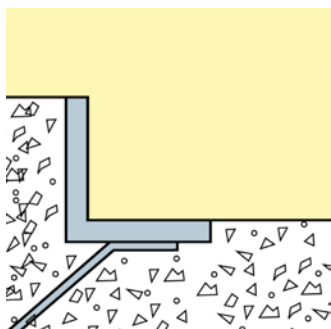

Kabe 17R

For mats and gratings height
15-20 mm.
Profile 20 x 20 x 3 mm.

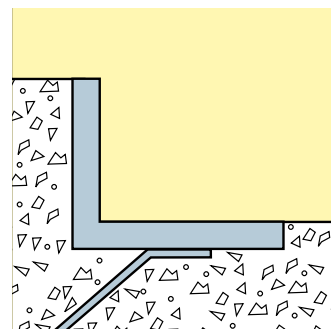

Kabe 20R

For mats and gratings height
20-22 mm.
Profile 25 x 31 x 4 mm.

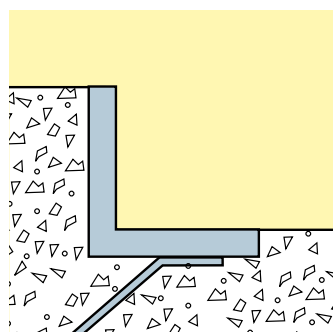

Kabe 22R

For mats and gratings height 2-22 mm.
Profile 25 x 25 x 3 mm.

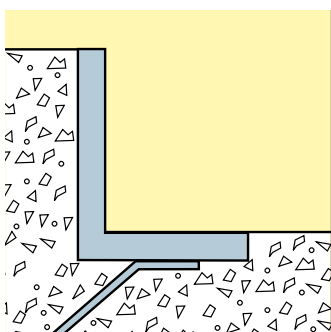

Kabe 25R

For mats and gratings height 25 mm.
Profile 31 x 25 x 4 mm.

Screw joint frame with intermediate brace

Fit the frame so that the notches/tracks are centred with each other.
Then place the T-profile in the tracks.



If necessary:

Turn the two outermost clasps on the underside at each end of the T-profile to keep it in position.

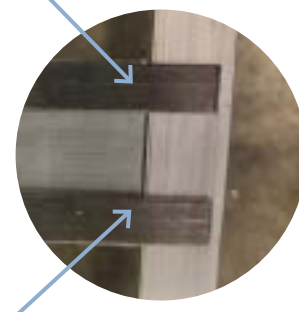

Ordering

When ordering please state exterior frame measurements. Please let us be responsible for the fitting of the mat or grid by ordering the casting frame and mat or grid at the same time. Always remember to state the measurements in the order A x B.

A = width, left to right.

B = front to back (walking direction).

Contact us for more information.